

JaHam[®] Model JT10

Truck Probe Sampling System

- Core Style Truck Probe Sampling System.
- Suitable for medium to large elevator applications.
- Supplied complete with all hydraulic, vacuum and electric components required.
- Short and long distance vacuum systems available.
- Hand held joystick operator controller supplied standard.
- Complete line of accessory items are available for all of our Truck Probe Sampling Systems.



The Model JT10 is the medium duty JaHam truck probe offering. It is ideal for use with all whole grains in low- to mid-volume grain elevator and processing facilities. Ruggedly built, it will provide your operators with years of use at an affordable price. The core style sampling head is the fastest and most accurate method for probing trucks.

Its proven track record provides you the sampling confidence required in your daily operations. Like all JaHam systems, the Model JT10 is provided with the hydraulic and vacuum systems pre-mounted, pre-plumbed and pre-wired for easy installation and use.



GAMET MANUFACTURING, INC.

7400 Boone Avenue North · Brooklyn Park, MN USA 55428

info@gametmfg.com · www.gametmfg.com

Toll Free 888-647-5475

JaHam®

Model JT10

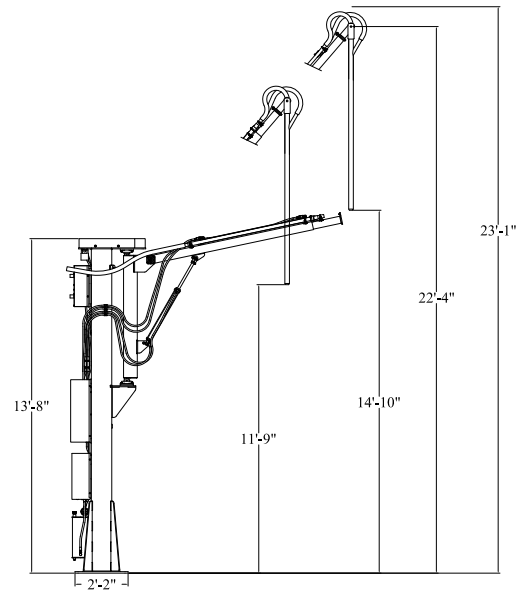
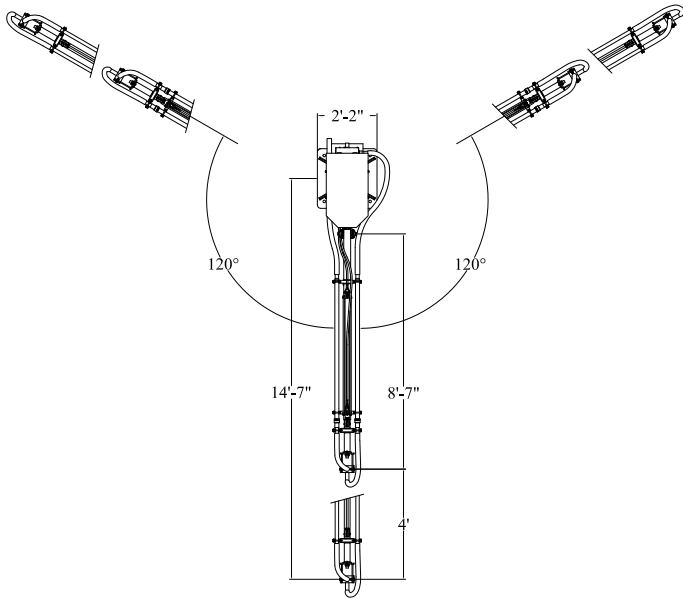

System Specifications

- Base: 26" x 26"
- Height: 13' 8"*
- Rotation: 240°*
- Reach: 12' 6"
- Core Probe Length: 7'*
- Hydraulic Pump: 2 HP, 3.6 GPM, 1,500 PSI
- System Voltage: 1/60/220*

* Other Options Available

Vacuum System Options

Standard Vacuum System: Supplied with a separate vacuum and clean air supply motor. Suitable for conveying product up to 120'.

Dual Vacuum System: Supplied with (2) separate vacuums and (1) clean air supply motor. Suitable for conveying product up to 250'.

Positive Displacement Pump System: Supplied with a separate vacuum pump and clean air supply motor. Suitable for conveying product in excess of 250'.

Available Accessories

Cyclone Style Collection System
Gravity Divider
Excess Sample Return Systems
One Way Scale Ticket Conveying System
Bi-Directional Scale Ticket Return System

Video Monitoring Equipment (CCTV)
Traffic Control Lights
Audio Intercom System
Signal Alarm

Tubing Support / Structure System: Engineered tubing support system provides a mounting mechanism for sample conveying tubing, electric conduit and a variety of truck probe system accessories. These easy to install systems are designed so no welding and special tooling is required.



GAMET MANUFACTURING, INC.
7400 Boone Avenue North · Brooklyn Park, MN USA 55428
info@gametmfg.com · www.gametmfg.com
Toll Free 888-647-5475